

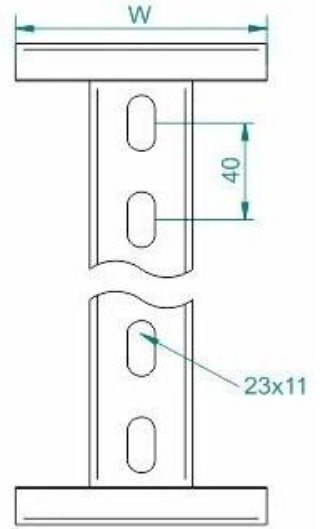

NPI Profil Merdiven Ara Bağlantı Elemanı STS-I80C

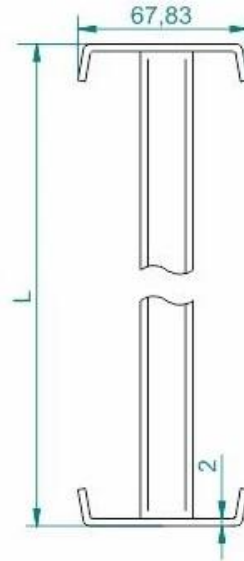

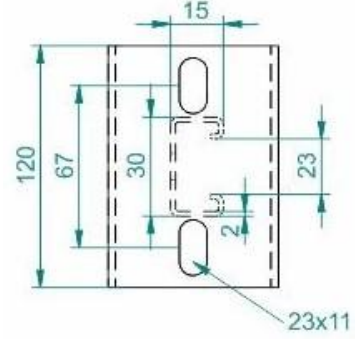

• Ölçüler mm. dir. - Dimensions in mm.



 Sıcak Daldırma Galvaniz - Hot Dip Galvanized

 Pregalvaniz - Pregalvanized

Ürün Kodu Product Code	W mm	L mm	 Kg ad/pce.	 Kg ad/pce.
STS I80-30C	120	300	-	1,179
STS I80-40C	120	400	-	1,340
STS I80-50C	120	500	-	1,501
STS I80-60C	120	600	-	1,662
STS I80-70C	120	700	-	1,823
STS I80-80C	120	800	-	1,984
STS I80-90C	120	900	-	2,145
STS I80-100C	120	1000	-	2,306
STS I80-120C	120	1200	-	2,629

Yüzey Koruma

Sıcak Daldırma Galvaniz TS 914
Pre-galvaniz TS 822
Elektrostatik Toz Boya

Surface Protection

Hot Dip Galv. ISO EN 1461
Pre-galvanization ISO EN 10143
Electrostatic Sprey Painting